

No.	DESCRIPTION	MATERIAL
1	KEY	LEAD FREE BRASS ALLOY ASTM B584
2	BODY	LEAD FREE BRASS ALLOY ASTM B584
3	KEY WASHER	CAST BRASS ALLOY ASTM B584
4	KEY NUT	CAST BRASS ASTM B62 ALLOY C83600

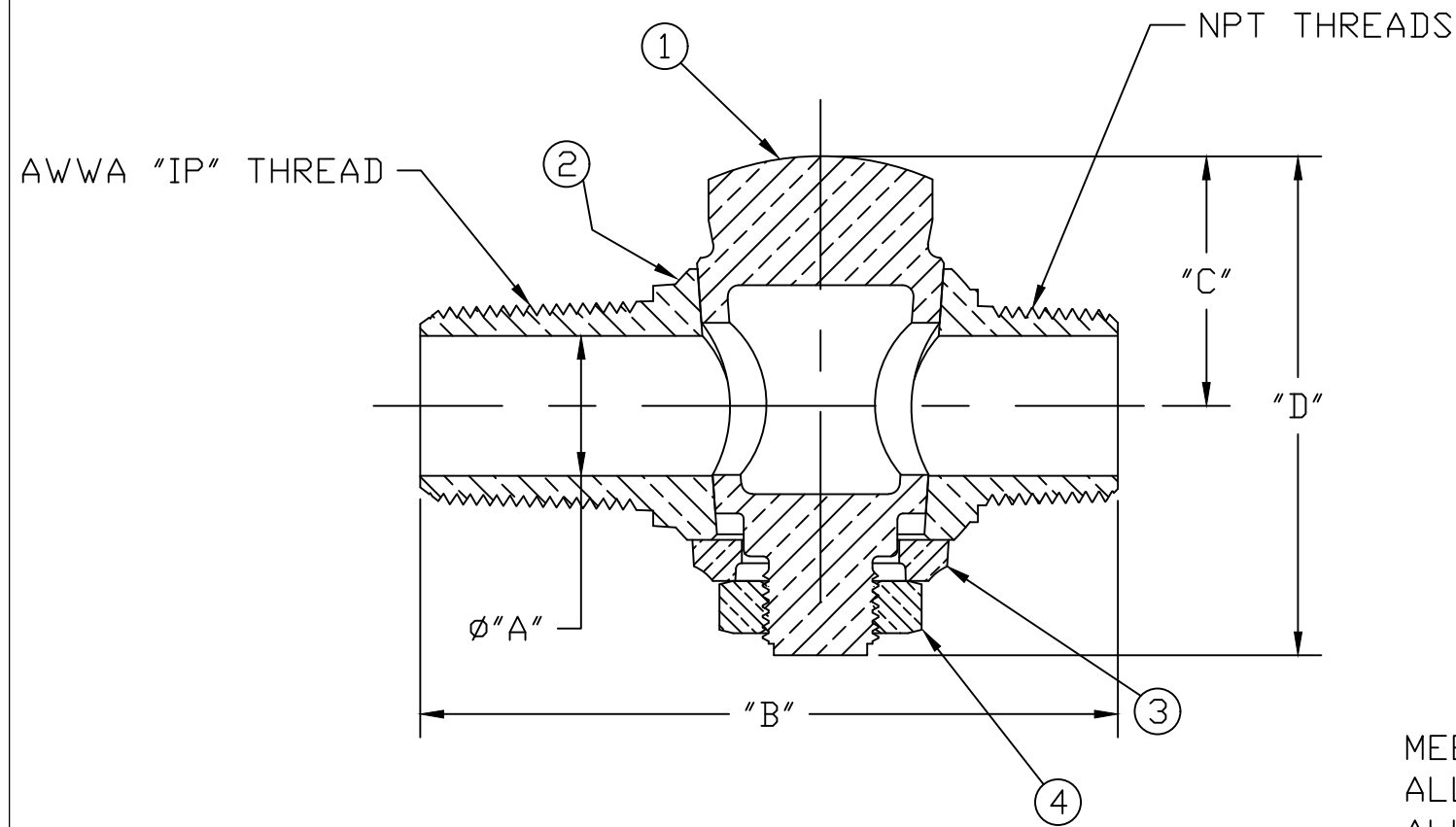

SIZE	ØA	B	C	D
1/2	.53	3.11	1.17	2.32
3/4	.78	3.81	1.30	2.68
1	1.03	4.36	1.41	2.87
1-1/4	1.28	5.23	1.80	3.80
1-1/2	1.53	6.03	2.16	4.49
2	2.03	7.14	2.42	4.91

MEETS ALL REQUIREMENTS OF AWWA C800
 ALL WETTED PARTS ARE LEAD FREE BRASS ALLOY C89833/C87850
 ALL NON WETTED PARTS ARE BRASS ALLOY C83600/C87850

DWG NUMBER
H10013N

TITLE TO AND OWNERSHIP OF THIS ENGINEERING
 DATA REMAINS IN Mueller Co. NO USE IS TO BE
 MADE OF THIS DATA EXCEPT AS SPECIFICALLY
 AUTHORIZED BY Mueller Co. ASSENT ON THE PART
 OF THE RECIPIENT TO THESE CONDITIONS IS PRESUMED

DRFTR	AD	02/02/23	MUELLER		
CHKR					
ENGR			UNLESS OTHERWISE NOTED SURFACE PREPARATION: BREAK CORNER(S) ---- .000 SURFACE FINISH -- XX RMS	THIRD ANGLE PROJECTION	
MGR				REF. No.	SCALE
	BY	DATE	TOLERANCE(S): LINEAR ----- ± .000 ANGULAR ----- ± 0°00'		NONE
STK No:			MAT'L:		
DESCR.			CORPORATION STOP VALVE ("AWWA IP" x "MIP")		DWG NUMBER H10013N