

No.	DESCRIPTION	MATERIAL
1	BODY	LEAD FREE BRASS ALLOY ASTM B584
2	KEY	LEAD FREE BRASS ALLOY ASTM B584
3	KEY WASHER	CAST BRASS ALLOY ASTM B584
4	KEY NUT	CAST BRASS ASTM B62 ALLOY C83600
5	COPPER GASKET	COPPER SHEET ASTM B152 UNS C11000
6	INSTA-TITE BODY	LEAD FREE BRASS ALLOY ASTM B584
7	O-RING	EP ASTM D2000
8	GRIP RING	CELCON M90 NATURAL CF2001

SIZE	ØA	B	C	D	E	F	G
3/4	.75	3.84	1.38	1.3	2.68	1.20	.38
1	.92	4.52	1.46	1.41	2.87	1.48	.38

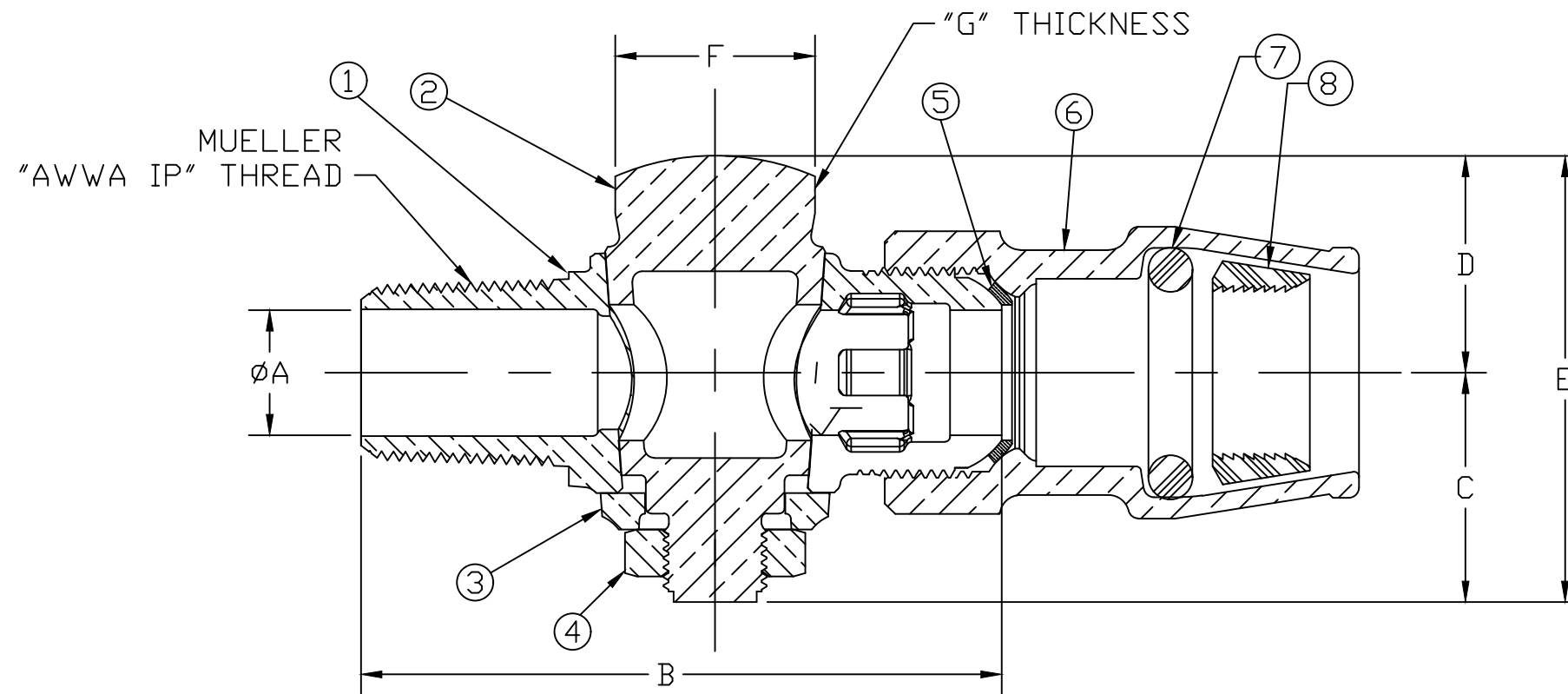

MEETS ALL REQUIREMENTS OF AWWA C800  
 ALL WETTED PARTS ARE LEAD FREE BRASS ALLOY C89833/C87850  
 ALL NON WETTED PARTS ARE BRASS ALLOY C83600/C87850

DWG NUMBER  
H15026N

DRFTR	AD	02/06/23	<b>MUELLER</b>	
CHKR				
ENGR			UNLESS OTHERWISE NOTED SURFACE PREPARATION: BREAK CORNER(S) ---- .000 SURFACE FINISH -- XX RMS	THIRD ANGLE PROJECTION
MGR				REF. No.
	BY	DATE	TOLERANCE(S): LINEAR ----- ± .000 ANGULAR ----- ± 0°00'	FULL
STK No:				
MAT'L:				
DESCR.			CORPORATION STOP (‘AWWA IP’ x INSTA-TITE)	
			DWG NUMBER H15026N	

TITLE TO AND OWNERSHIP OF THIS ENGINEERING  
 DATA REMAINS IN Mueller Co. NO USE IS TO BE  
 MADE OF THIS DATA EXCEPT AS SPECIFICALLY  
 AUTHORIZED BY Mueller Co. ASSENT ON THE PART  
 OF THE RECIPIENT TO THESE CONDITIONS IS PRESUMED