

No.	DESCRIPTION	MATERIAL
1	BODY	LEAD FREE BRASS ALLOY ASTM B584
2	KEY	LEAD FREE BRASS ALLOY ASTM B584
3	KEY WASHER	CAST BRASS ALLOY ASTM B584
4	KEY NUT	CAST BRASS ASTM B62 ALLOY C83600
5	IPS PE GSKT	ASTM D2000(SBR)&410 STAINLESS STEEL
6	CONNX NUT	CAST BRASS ALLOY ASTM B584

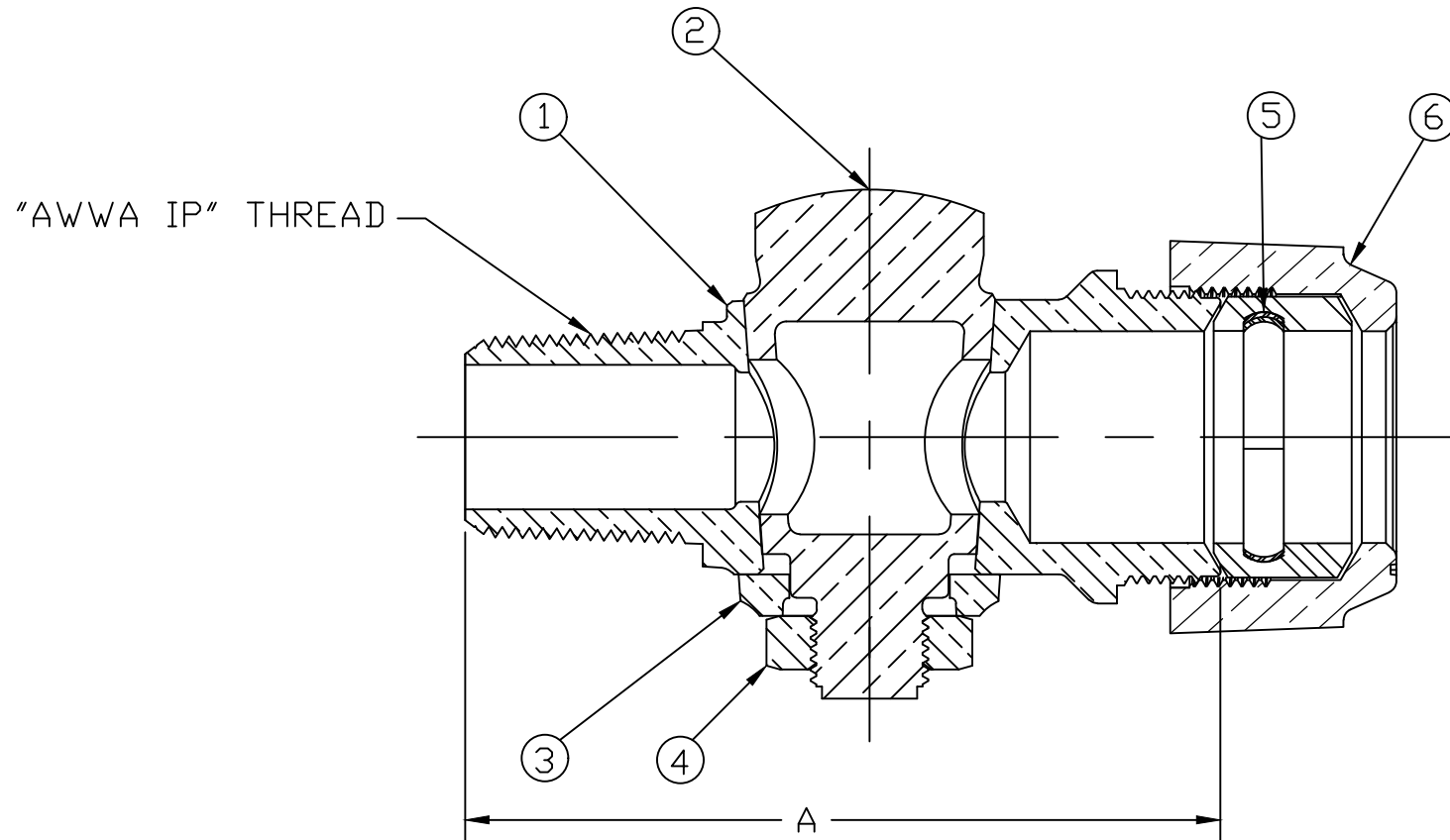

VALVE SIZE	A
3/4"	3.97
1"	5.98

MEETS ALL REQUIREMENTS OF AWWA C800  
 ALL WETTED PARTS ARE LEAD FREE BRASS ALLOY C89833/C87850  
 ALL NON WETTED PARTS ARE BRASS ALLOY C83600/C87850

DRFTR	AD	02/03/23	<b>MUELLER</b>	
CHKR				
ENGR			UNLESS OTHERWISE NOTED SURFACE PREPARATION: BREAK CORNER(S) ---- .000 SURFACE FINISH -- XX RMS	THIRD ANGLE PROJECTION
MGR				REF. No.
	BY	DATE	TOLERANCE(S): LINEAR ----- ± .000 ANGULAR ----- ± 0°00'	
STK No:				
MAT'L:				
DESCR.	GROUND KEY CORPORATION VALVE (AWWA IP x 110IPS)			DWG NUMBER H15029N

DWG NUMBER  
H15029N

TITLE TO AND OWNERSHIP OF THIS ENGINEERING  
 DATA REMAINS IN Mueller Co. NO USE IS TO BE  
 MADE OF THIS DATA EXCEPT AS SPECIFICALLY  
 AUTHORIZED BY Mueller Co. ASSENT ON THE PART  
 OF THE RECIPIENT TO THESE CONDITIONS IS PRESUMED