

NOMINAL MAIN SIZE	CAST IRON O.D. PVC PIPE				IPS PVC PIPE			
	C.C. TAPPING SIZE CATALOGUE SERIES #		F.I.P.T. TAPPING SIZE CATALOGUE SERIES #		C.C. TAPPING SIZE CATALOGUE SERIES #		F.I.P.T. TAPPING SIZE CATALOGUE SERIES #	
	.75"	1"	.75"	1"	.75"	1"	.75"	1"
2"	---		---		S-13420		S-13470	
2.5"	---		---		S-13422		S-13472	
3"	---		---		S-13425		S-13475	
4"	S-13440		S-13490		S-13428		S-13478	
6"	S-13441		S-13491		S-13431		S-13481	
8"	S-13442		S-13492		S-13433		S-13483	

TAPPING SIZE (SEE TABLE)

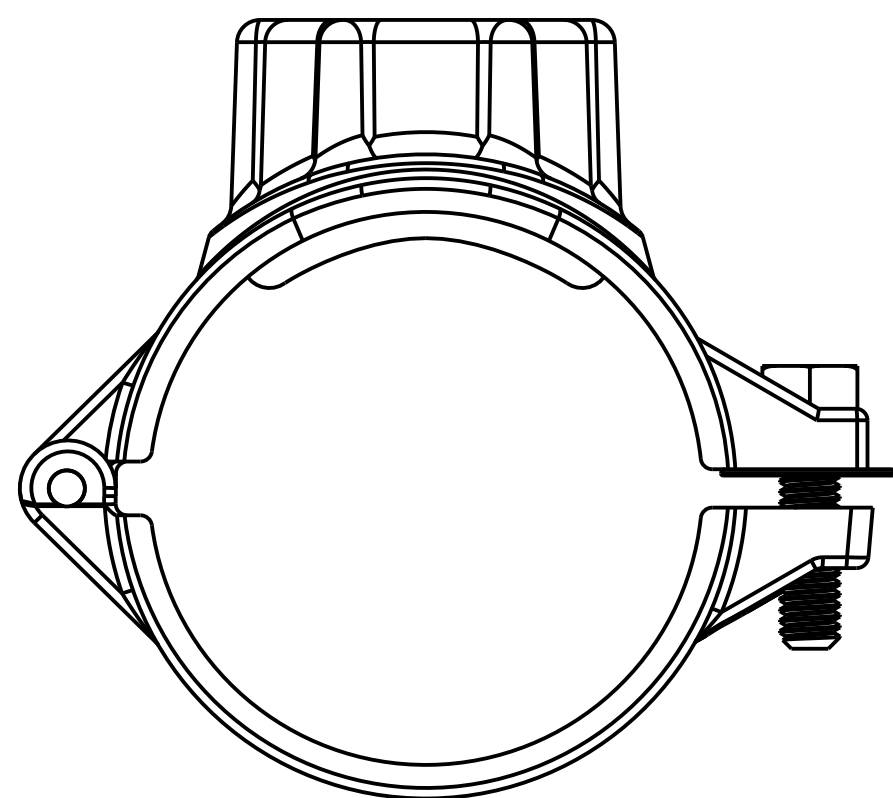
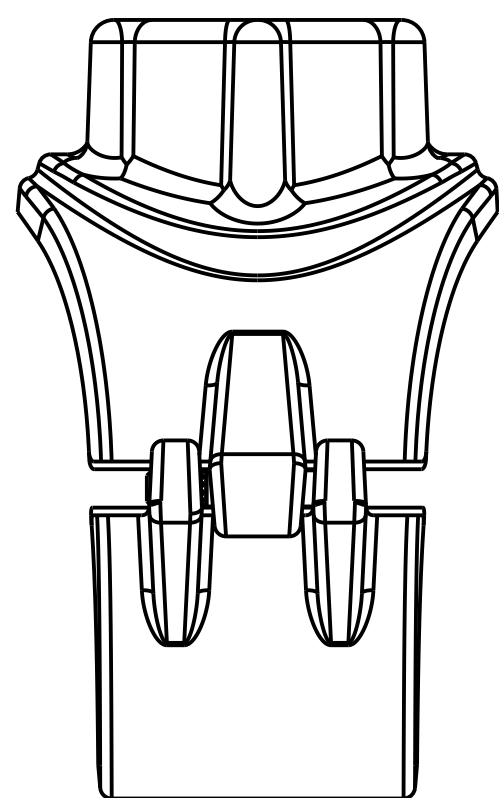
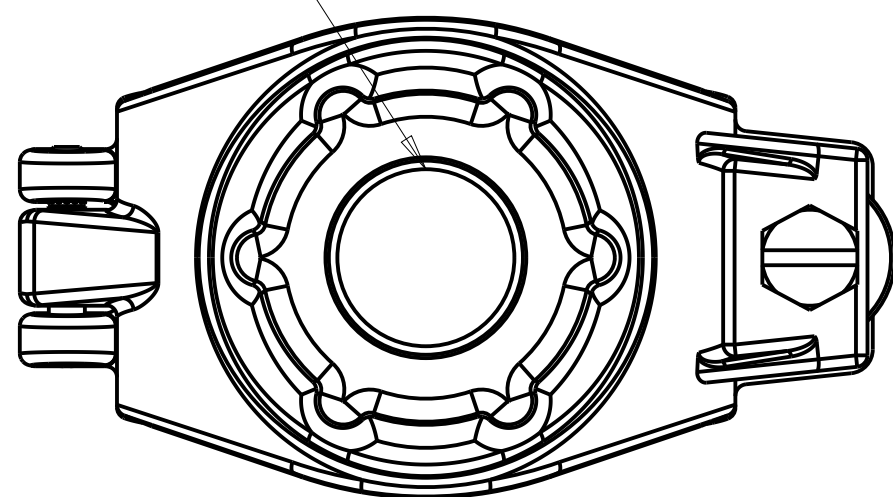

(B)

CAST BRONZE
ASTM B62 ALLOY C83600

SILICON BRONZE

NITRILE O-RING

SILICON BRONZE

(B)

CAST BRONZE
ASTM B62 ALLOY C83600

POLYETHYLENE WASHER

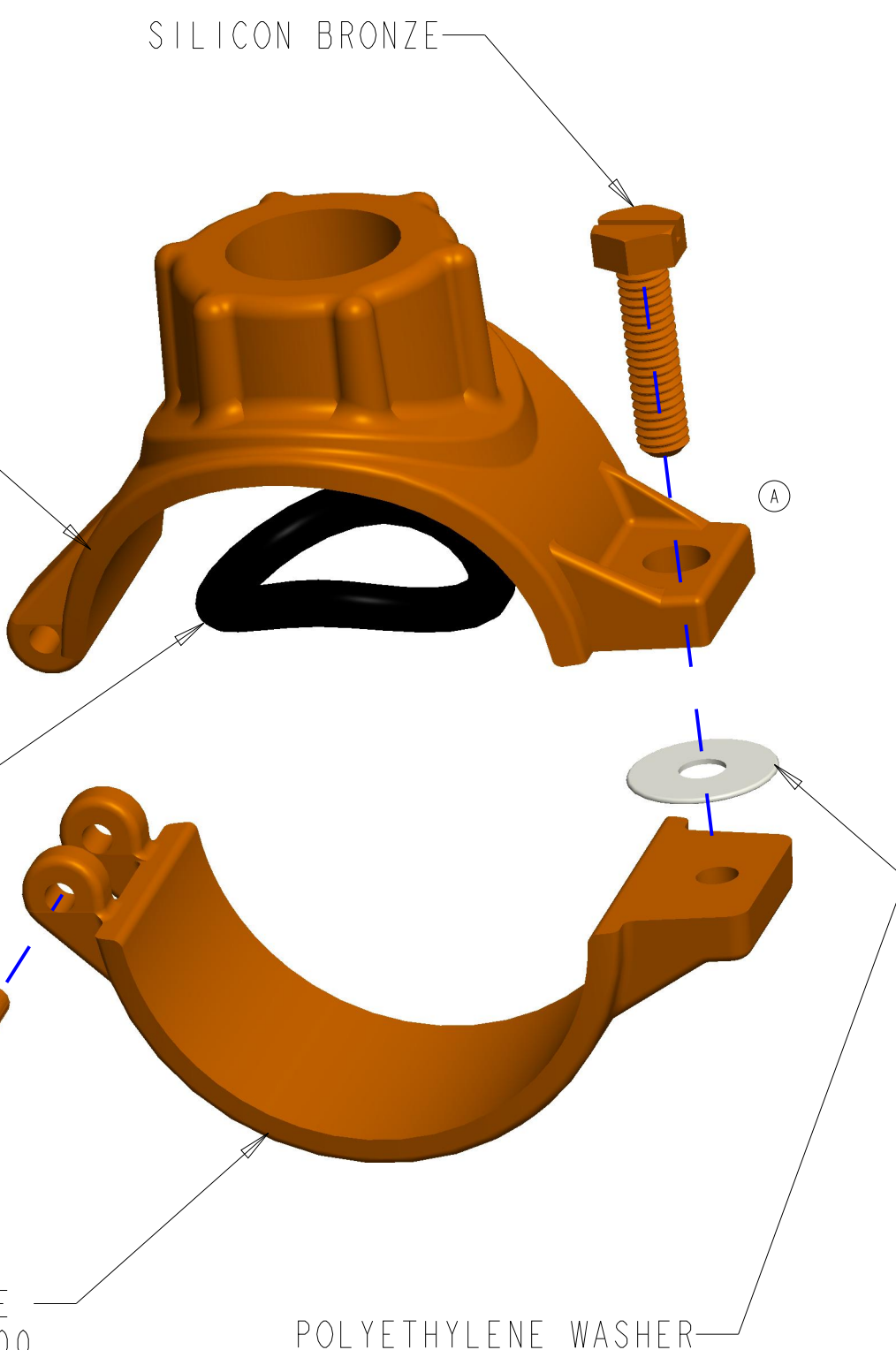

DR. BY	DLG	08/14/14	UNLESS OTHERWISE NOTED	THIRD ANGLE PROJECTION	C.B. NO.
CHKR			BREAK CAST CORNER(S)---		
ENGR			BREAK MACH CORNER(S)---	PURCH.	FINISH
MGR			TOLERANCES	REF. NO.	PATT. NO.
MFG			UNLESS OTHERWISE NOTED	SCALE	
TOOL			LINEAR	1.000	
FDRY			±	STR. NO.	
MAT'L:					
Mueller Co.			DESCR.	NUMBER	
			S-13000 SERVICE SADDLES		SBM-S-13000

ADDED TABLE AND MATERIAL INFORMATION
DLG (A) 03/23/15

(B)

ADDED CAST BRONZE MATERIAL INFORMATION
TBE 11/3/17