

No.	DESCRIPTION	MATERIAL
1	METER FLANGE	CAST LOW LEAD BRASS ALLOY
2	PJ GASKET	ASTM D2000 (BUNA N)
3	PJ WASHER	POLYPROPYLENE
4	PJ CPLG NUT	CAST BRASS ASTM B62 ALLOY C83600

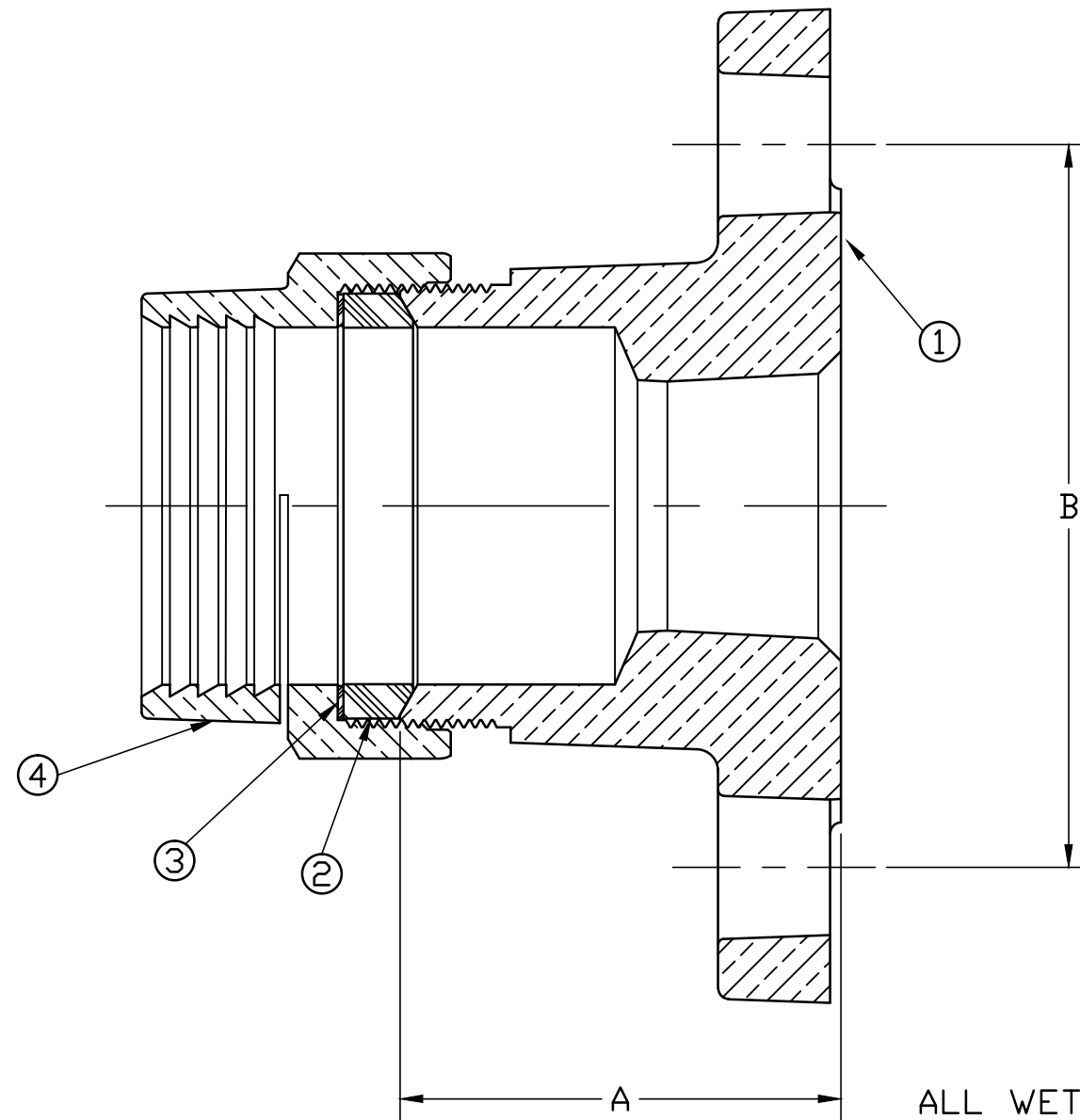

SIZE	A	B
1-1/2	2.56	4.00
2	2.81	4.50

ALL WETTED PARTS ARE LOW LEAD BRASS ALLOY

FILEPATH: PROD-ENG\MUELLER\ASYSUBMITTALS\V10120N

						DRFTR	JGarvin	9/23/10	Mueller Co.		
						CHKR					
						ENGR					
						MGR					
									UNLESS OTHERWISE NOTED	THIRD ANGLE PROJECTION	
									SURFACE PREPARATION:		
									BREAK CORNER(S) ---- .000		
									SURFACE FINISH -- XX RMS	REF. No.	SCALE
									TOLERANCE(S):		FULL
									LINEAR ----- ± .000		
									ANGULAR ----- ± 0°00'		
									STK No:		
									MAT'L:		
									DESCR.	LLB METER FLANGE SERVICE FITTING (MTR FLG x PJ IPS PVC)	DWG NUMBER V10120N
REV	ECR	DESCRIPTION	DATE	BY	CHKR						
PER EST NO: DXXXX EST FIN WT = 0.0000 lbs											

TITLE TO AND OWNERSHIP OF THIS ENGINEERING DATA REMAINS IN Mueller Co. NO USE IS TO BE MADE OF THIS DATA EXCEPT AS SPECIFICALLY AUTHORIZED BY Mueller Co. ASSENT ON THE PART OF THE RECIPIENT TO THESE CONDITIONS IS PRESUMED.

DWG NUMBER
V10120N
442-MRKTG