

No.	DESCRIPTION	MATERIAL
1	SPUD	CAST LOW LEAD BRASS ALLOY
2	COMP GSKT	NITRILE ASTM D2000
3	WASHER	POLYPROPYLENE
4	CPLG NUT	CAST BRASS ASTM B62 ALLOY C83600

SIZE	A	B
1"	2.000	2.000
1-1/2"	2.969	2.969
2"	3.625	3.625

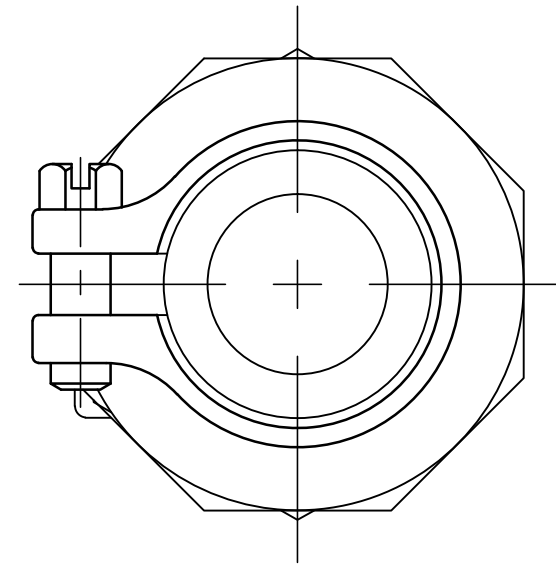
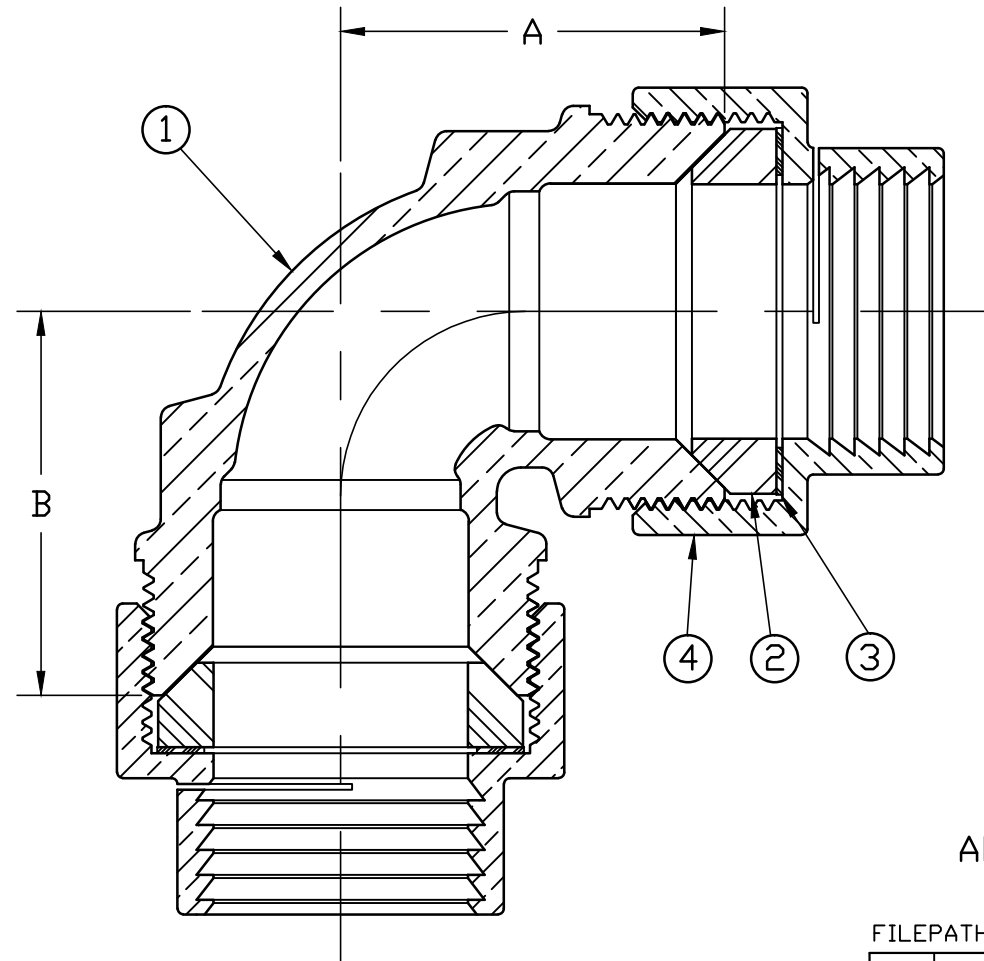

ALL WETTED PARTS ARE LOW LEAD BRASS ALLOY

FILEPATH: PROD-ENG\MUELLER\ASYSUBMITTALS\V15111N

						DRFTR	RWB	4/26/16	Mueller Co.		
						CHKR					
						ENGR					
						MGR					
									UNLESS OTHERWISE NOTED	THIRD ANGLE PROJECTION	
									SURFACE PREPARATION:		
									BREAK CORNER(S) ---- .000		
									SURFACE FINISH -- XX RMS	REF. No.	SCALE
									TOLERANCE(S):		NONE
									LINEAR ----- ± .000		
									ANGULAR ----- ± 0°00'		
									STK No:		
									MAT'L:		
									DESCR.	90° ELL LLB SERVICE FITTING (IPS PVC PJ x IPS PVC PJ)	DWG NUMBER V15111N
REV	ECR	DESCRIPTION	DATE	BY	CHKR						
PER EST NO: DXXXX EST FIN WT = 0.0000 lbs											

DWG NUMBER
V15111N
442-MRKTNG