

No.	DESCRIPTION	MATERIAL
1	SPUD	CAST LOW LEAD BRASS ALLOY
2	COMP GSKT	NITRILE ASTM D2000
3	WASHER	POLYPROPYLENE
4	CPLG NUT	CAST BRASS ASTM B62 ALLOY C83600
5	COMP GSKT	BUNA N ASTM D2000
6	WASHER	POLYPROPYLENE
7	CPLG NUT	CAST BRASS ASTM B62 ALLOY C83600

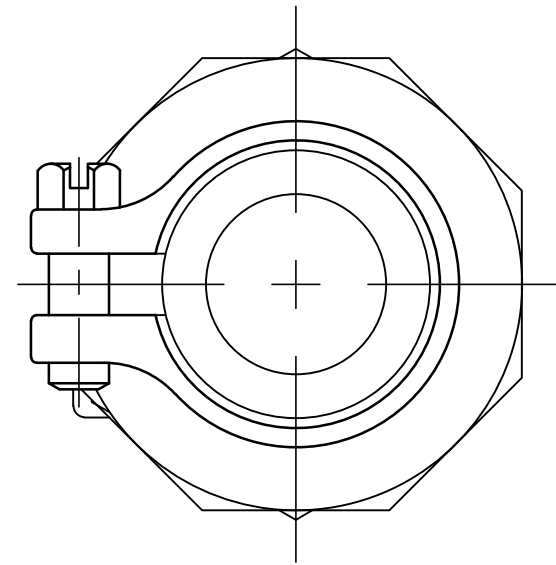
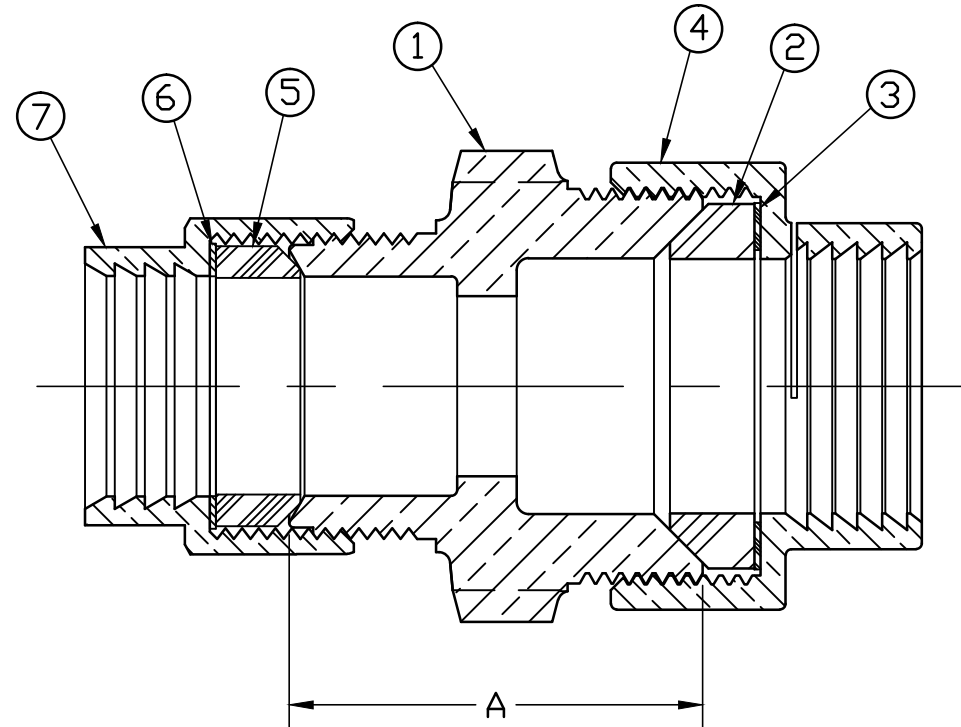

SIZE	A
1"	2.15
1" x 3/4"	2.14
1 1/2"	2.74
1 1/2" x 3/4"	2.64
2"	2.91

ALL WETTED PARTS ARE LOW LEAD BRASS ALLOY

FILEPATH: PROD-ENG\MUELLER\ASYSUBMITTALS\V15441N

						DRFTR	RWB	3/5/15	<b>Mueller Co.</b>		
						CHKR					
						ENGR					
						MGR					
									UNLESS OTHERWISE NOTED	THIRD ANGLE PROJECTION	
									SURFACE PREPARATION:		
									BREAK CORNER(S) ---- .000		
									SURFACE FINISH -- XX RMS	REF. No.	SCALE
									TOLERANCE(S):		FULL
									LINEAR ----- ± .000		
									ANGULAR ----- ± 0°00'		
									STK No:		
									MAT'L:		
									DESCR.		
										LLB SERVICE FITTING	DWG NUMBER
										CTS 110 x PJ (IPS PVC)	V15441N
REV	ECR	DESCRIPTION	DATE	BY	CHKR	PER EST NO: DXXXX EST FIN WT = 0.00000 lbs					

DWG NUMBER  
V15441N  
442-MRKTG

TITLE TO AND OWNERSHIP OF THIS ENGINEERING DATA REMAINS IN Mueller Co. NO USE IS TO BE MADE OF THIS DATA EXCEPT AS SPECIFICALLY AUTHORIZED BY Mueller Co. ASSENT ON THE PART OF THE RECIPIENT TO THESE CONDITIONS IS PRESUMED.